

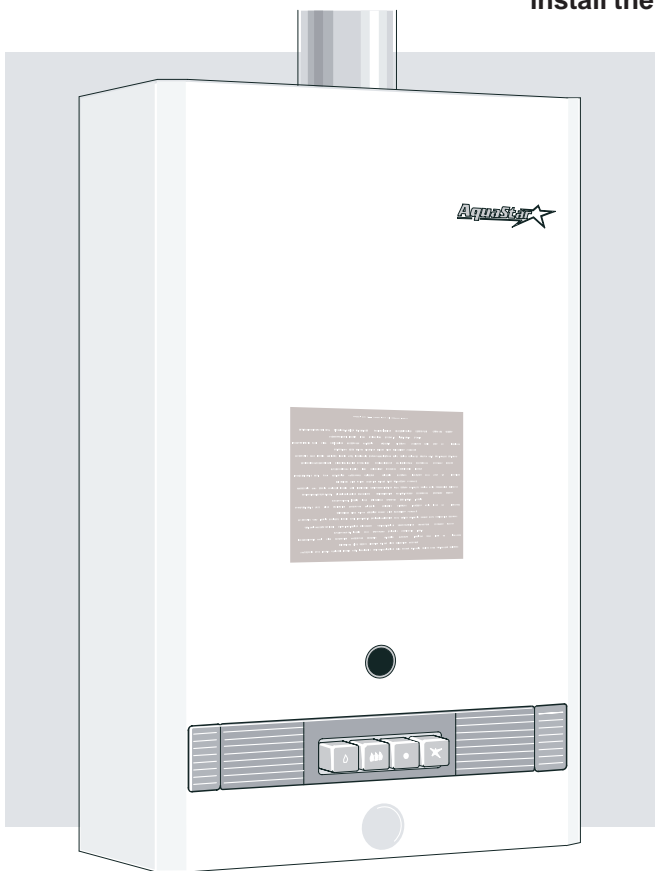

INSTALLATION AND OPERATING INSTRUCTIONS FOR AUTOMATIC INSTANTANEOUS TYPE WATER HEATERS FOR USE WITH NATURAL AND LIQUEFIED PETROLEUM GAS

MODEL 125B LPS and 125B NGS (Thermostatically Modulated) Suitable for water (potable) heating

Intended for domestic hot water with preheated inlet water as with solar hot water. For domestic hot water applications with cold water inlet, install the 125B model. For constant flow, recirculating applications, install the 125BL model.



WARNING

If the information in this manual is not followed exactly, a fire or explosion may result causing property damage, personal injury or death.

FOR YOUR SAFETY

Do not store or use gasoline or other flammable, combustible or corrosive vapors and liquids in the vicinity of this or any other appliance.

WHAT TO DO IF YOU SMELL GAS

- Do not try to light any appliance.
- Do not touch any electrical switch; do not use any phone in your building.
- Immediately call your gas supplier from a neighbor's phone. Follow the gas supplier's instructions.
- If you cannot reach your gas supplier, call the fire department.
- Installation and service must be performed by a qualified installer, service agency or the gas supplier.

TABLE OF CONTENTS

Specifications	Page 2
Rules for safe operation	Page 4
Locating the Heater	Page 5
Combustion Air Requirements	Page 5
Mounting the Heater	Page 6
Venting the Heater	Page 6
Gas Connections	Page 7
Water Connections	Page 7
Safety before lighting the pilot	Page 8
Lighting instructions	Page 8
Information on water temperature	Page 9
Maintenance & Service	Page 9
Trouble Shooting	Page 10
Diagram of AquaStar	Page 13
Components and Parts List	Page 14

WARNING: Improper installation, adjustment, alteration, service or maintenance can cause injury or property damage. Refer to this manual. For assistance or additional information consult a qualified installer, service agency or the gas supplier. Upon completion of the installation, these instructions should be handed to the user of the appliance for future reference.

FEATURING: Automatic Variable Power Modulating Gas Valve with Thermostatic Control

Warning: If you do not follow these instructions exactly, a fire or explosion may result causing property damage, personal injury or loss of life.

This well engineered, gas water heater has been specially designed to operate with incoming pre-heated water:

It operates on the principle of heating water instantaneously "on demand". When a hot water faucet is opened, cold water flows through the coils of the heat exchanger in the Aquastar. This same flow opens the gas valve, and the burners are ignited by the pilot flame. The heat exchanger coils absorb the heat generated by the burners and transfer heat to the water. When the hot water faucet is shut off, the gas valve automatically closes and the burners turn off. Your hot water faucet is an ignition key to turn on the water heater, giving you control over your hot water energy use. Each time you turn off your hot water faucet, you also shut off the water heater. On the Aquastar "S" model, if the incoming water is colder than the thermostat setting of the heater, the burners will ignite to heat the water in order to boost it and maintain it at the temperature setting. If the incoming water has been pre-heated, (ie) solar, and this water temperature is warm then the the burners will modulate down accordingly, or shut down completely if the temperature is as hot or hotter than the heater thermostat setting. The Aquastar 125 BS is the perfect backup to a solar hot water system.

FEATURES

- High Quality Materials for Long Working Life.
- Copper heating coils for endless supply of hot water.
- Burner output proportional to hot water flow demand for maximum energy efficiency.
- Automatic Thermostatic Control for steady hot water temperature
- Input BTU's modulate to zero to prevent overheating of water from pre-heat source
- Safety thermocouple at pilot burner.
- Automatic overheating protection shut-off sensor.
- Stainless steel burners with stabilized blue flame.
- Built-in corrosion resistant draft inducer.
- Compact space saver: mounts on a wall with two hooks.
- Easily removable one-piece cover.
- Easy one person installation.
- Adjustable water flow restrictor to ensure that water flow demand will not exceed the heating capacity of the heater.
- Easy pilot flame lighting with push button piezo ignition.

AquaStar 125B LPS and 125B NGS Specifications

Gas Input max.: 117,000 Btu/hr
min.: 23,400 Btu/hr

Water Connection 1/2" Thread fitting

H x W x D 29 3/4" x 18 1/4" x 8 3/4"

Vent 5"

Gas Connection 1/2" NPT thread

Min. Water Pressure 18 Psi at 4 GPM

Max. Water Pressure 150 Psi

Shipping Weight 44 LB

Net Weight 42 LB

1.8 GPM at 90° rise

3.7 GPM at 45° rise

Min. Water Flow 1/2 gal/min

LP GAS Supply Pressure inlet. min. 11" W.C.
max. 14" W.C.*

LP GAS Manifold pressure 9.0" W.C.**

Natural Gas Pressure inlet min.: 7" W.C.
max.: 14" W.C.*

Natural Gas Manifold Pressure 4.2 W.C.**

* Inlet gas pressure must not exceed this value

** For purposes of input adjustment

UNPACKING THE AQUASTAR HEATER

This heater is packed securely. The box includes two water connection fittings, a gas pressure regulator, an incandescent particle tray, two hooks for hanging the heater, this manual, a personal letter, a warranty statement and a warranty registration card. Do not lose this manual, as there is a charge for replacement. Please complete and return the enclosed warranty registration card.

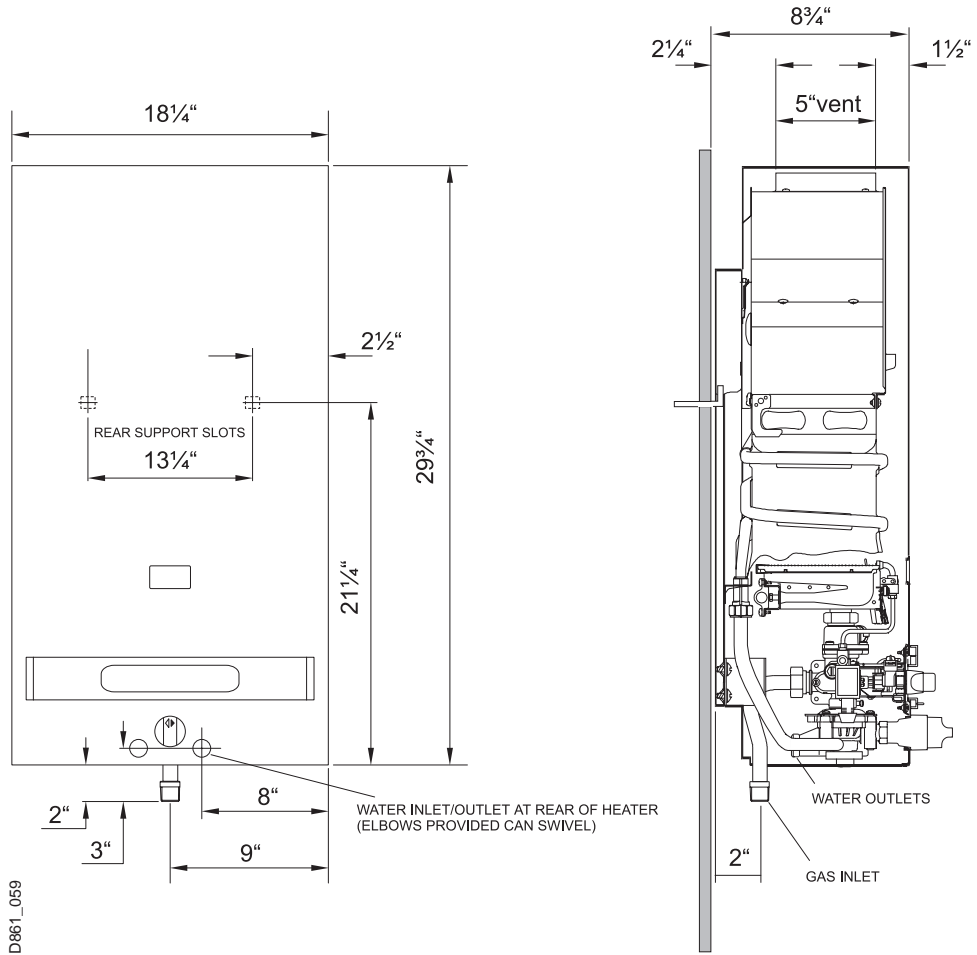

FRONT VIEW

SIDE VIEW

MINIMUM INSTALLATION CLEARANCES FROM COMBUSTIBLE AND NON COMBUSTIBLE MATERIALS FOR ALCOVE INSTALLATIONS

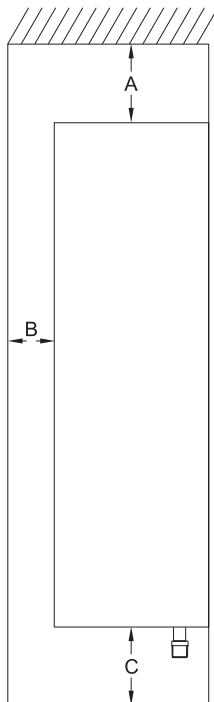

	MODEL 125B / 125B LOW PRESSURE / 125B SOLAR / 125X
TOP (A)	12"
FRONT (B)	OPEN
BACK	0"
SIDES	4"
FLOOR (C)	12"
FLUE DIAMETER	5"

AQUASTAR MODELS 125B / 125BL / 125BS / 125X

GENERAL RULES TO FOLLOW FOR SAFE OPERATION

1. You should follow these instructions when you install your heater. In the United States: The installation must conform with local codes or, in the absence of local codes, the National Fuel Gas Code ANSI Z223.1/NFPA 54.

In Canada: The Installation should conform with CGA B149.(1,2) INSTALLATION CODES and/or local installation codes.

2. Carefully plan where you install the heater. Correct combustion air supply and flue pipe installation are very important. If not installed correctly, fatal accidents can be caused by lack of air, carbon monoxide poisoning or fire.

3. The place where you install the heater must have enough ventilation. The National Fire Codes do not allow water heater installation in bathrooms, bedrooms or any occupied rooms normally kept closed. See the section below on locating the heater.

4. You must vent your heater. See section on Vent Pipe Connections, Page 4.

5. The appliance must be disconnected from the gas supply piping system during any pressure testing at pressures in excess of 1/2 Psig (3.5 kPa).

The appliance must be isolated from the gas supply piping system by closing its individual manual shutoff valve during any pressure testing of the gas supply piping system at test pressures equal to or less than 1/2 Psig (3.5Kpa). The appliance and its gas connection must be leak tested before placing the appliance in operation.

6. Keep water heater area clear and free from combustibles and flammable liquids. Do not locate the heater over any material which might burn.

7. **Correct gas pressure** is critical for the optimum operation of this heater (see specifications on page 2). Gas piping must be sized to provide the required pressure at the maximum output of the heater, while all the other gas appliances are in operation. Check with your local gas supplier, and see the section on connecting the gas supply.

8. Should overheating occur or the gas supply fail to shut off, turn off the gas supply at the manual gas shut off valve on the gas line.

9. Do not use this appliance if any part has been underwater. Immediately call a qualified service technician to inspect the appliance and to replace any part of the control system and any gas control which has been underwater.

PROPER LOCATION FOR INSTALLING YOUR HEATER

Carefully select the location of your new heater. For your safety and for proper heater operation, you must provide an abundant supply of combustion air and a proper venting installation.

The heater may still operate even when improperly vented. It will, however, be less efficient and could eventually damage the heater. It could even result in human sickness or death due to oxygen deprivation and carbon monoxide poisoning. Follow the guidelines below:

1. Place your heater as close to a vent or chimney as possible.

2. National building codes require that you do not install this appliance in bathrooms, bedrooms, unvented closet or any occupied rooms normally kept closed.

3. Simultaneous operation of other appliances such as exhaust fans, ventilation systems, clothes dryers, fireplaces or wood stoves could create a vacuum effect in your home which could cause dangerous combustion by-products to spill back into your home rather than venting to the outside through the flue. Confirm that your Aquastar is venting properly when all these other appliances are running. See section on venting.

Do not obstruct the flow of combustion and ventilation air to the appliance. If installed near a clothes dryer it is very important that the dryer be properly vented. Failure to properly vent a dryer could result in a gradual accumulation of lint on the water heater fin coils and burners, leading to a dangerous condition of venting blockage and poor unsafe combustion.

COMBUSTION AIR REQUIREMENTS

Observe the following instructions concerning combustion air.

Appliances located in unconfined spaces:

- a) An unconfined space is one whose volume is greater than 50 cubic feet per 1000 Btu per hour of the combined rating of all appliances installed in the space. That would be 5850 cubic feet for the AquaStar 125B "S" alone.
- b) In unconfined spaces in buildings of conventional frame, masonry, or metal construction, infiltration is normally adequate to provide air for combustion, ventilation, and dilution of flue gasses.

Appliances located in confined spaces:) The confined space must be provided with two permanent openings, one commencing within 12 inches of the top and one commencing within 12 inches of the bottom of the enclosure. Each opening must have a minimum free area of one square inch per:

- 1000 Btu/hr if all air is taken from inside the building.
- 2000 Btu/hr if all air is taken from the outside by horizontal ducts.
- 4000 Btu/hr if all air is taken from the outside by direct openings or vertical ducts.

Louvers, grills and screens have a blocking effect. If the effective free area is not known, increase the sizes of your openings by 75% if your louvers are wood and by 30% if your louvers are metal. Refer to the National Fuel Gas Code for complete information. In buildings of tight construction all air should be taken from outside.

CLEARANCES

The Aquastar 125 B "S" is design certified for installation on a combustible wall and for installation in an alcove with the minimum clearances to combustible and non - combustible construction listed below

- A. Top 12 inches (305 mm)
- B. Front Open
- C. Back 0 inches
- D. Sides 4 inch (102mm)
- E. Bottom 12 inches (306 mm)

Note: Minimum clearance to combustible materials should not be less than 6" for single wall flue pipe. Note that this clearance can be reduced if combustible material are protected as per table VI of the National fuel Gas Code or if Type B gas vent is used.

MOUNTING INSTALLATION

The Aquastar 125 B "S" is design certified for mounting on a wall.

Do not install this appliance on a carpeted wall or over floor covering which is combustible, such as carpet. The heater must be mounted on a wall using appropriate anchoring materials. If wall is a stud wall sheathed with plasterboard, **it is recommended that support board(s), either 1x4's or 1/2" (minimum) plywood first be attached across a pair of studs and then the heater should be attached to the support boards. See Fig 1.** Expansion and contraction of piping due to changing water temperature in the pipes imparts movement to the heater which, if mounted directly to a brittle, friable board, such as plasterboard, can cause failure of mounting.

Before installing the unit, be certain you have the correct heater for your type of Gas – Propane or Natural Gas. Identification labels are found on the shipping box, and on the rating plate which is located on the right side panel of the cover. Also, each burner orifice is stamped with a number (79 for LPG and 120 for Natural Gas).

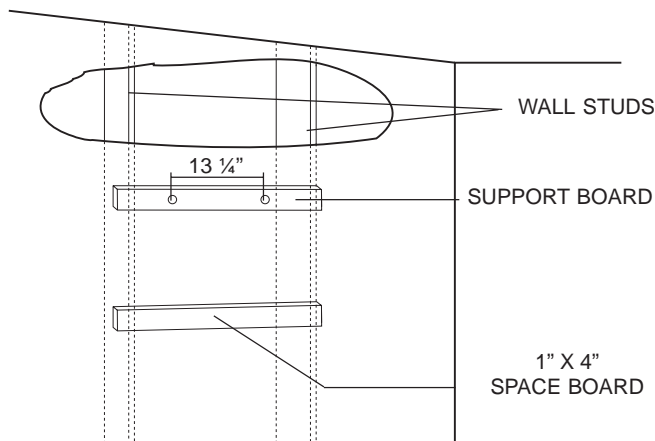

Fig. 1 - Mounting the Heater

The incandescent particle tray (shipped loose in the carton with the water heater) must be attached at the bottom of the water heater front cover at the time of installation. Use the screws provided. See figure 2

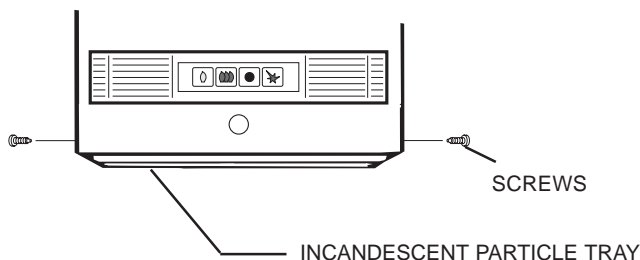

Fig. 2 - Incandescent Particle Tray Illustration

VENTING

Vent pipe connection. WARNING: Do not reduce the vent pipe size.

This appliance must be vented to the outside following all local ordinances and specifications for installing a gas appliance vent or chimney. The venting system must be designed and constructed so as to develop a positive flow

adequate to remove flue gasses to the outdoors. **Minimum vent size must be 5". Minimum height must be 6 feet, provided there are no elbows. Termination of vent must be 2 feet above any obstruction within a 10 foot radius. Consult your gas utility or National Fuel Gas Code if vent will have elbows or share venting with another appliance. The vent connector should have as much vertical rise as possible (minimum 12") before any horizontal run.**

Optional powervent available in order to sidewall vent. Contact your local dealer. The appliance must be located as close as practicable to a chimney or vent. The vent pipe sections must be secured to each other with sheet metal screws. Keep in mind the minimum clearance from the top of your heater. Remember also that single wall vent pipe connectors require a 6 inch clearance from combustibles. National Fuel Gas Code specifies double wall — Type "B" — vent pipe be used in cold climates and for gas vents running through attics. We consider double wall vent pipe preferable in all circumstances. Any vent section greater than 45 degrees from vertical is considered horizontal. Horizontal sections of vent connectors must slope upwards at least 1/4 inch for every foot of its horizontal length. Keep the horizontal section short and avoid too many elbows.

WARNING

Note: The burners of an instantaneous "on demand" water heater such as the AquaStar are only on at the time that hot water is actually being used, the venting stack is therefore cold except for the short durations when hot water is being used, it is therefore very important that the venting and air supply be adequate to provide a good positive draft as soon as the burners turn on. See venting guide on back page.

The AquaStar 125B"S" instantaneous water heaters have built-in draft diverters and are designed for indoor installation only. The draft diverter outlet must be connected to a clear, unobstructed vent of the same size, or larger.

In Canada, CAN/CGA-B149 Installation Code for detailed requirements

In U.S.A., ANSI Z223.1 - NFPA 54, national Fuel Gas Code for detailed requirements.

The flue connection for the AquaStar 125B"S" is 5 inches. However, in Canada, for installations at high altitude (2000-4500 feet above sea level) a six inch flue is required. A 5" by 6" flue adaptor must be affixed to the flue collar of the AquaStar with at least two screws. See figure 3

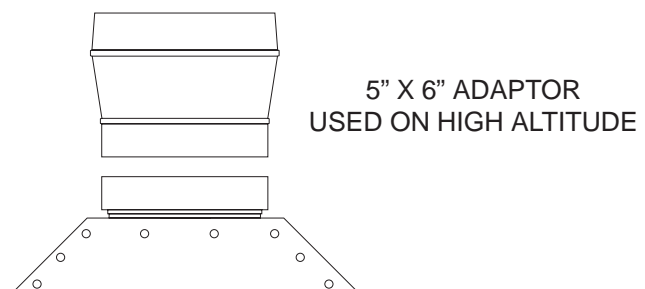

Fig. 3 - Flue Adaptor for High Altitude Installations

WARNING: Failure TO INCREASE THE VENT SIZE TO SIX INCHES AND/or assure that the manifold pressure is set to proper value listed for applications at high altitudes will cause unsafe venting, asphyxiation, and will void IAS Certification.

GAS CONNECTIONS and Gas Regulator

Before connecting the gas supply, check the rating plate on the right side of the front cover to be sure that the heater is rated for the same gas to which it will be connected.

In the United States: The installation must conform with local codes or, in the absence of local codes, the National Fuel Gas Code ANSI Z223.1/NFPA 54.

In Canada: The Installation should conform with CGA B149 INSTALLATION CODES and /or local installation codes.

NOTE: The Aquastar 125 B”S” is supplied with a gas pressure regulator that must be installed on the heater before attaching the gas supply line. See figure 4. Failure to install the gas regulator as shown in figure 4 will be a violation of IAS certification of the unit. The regulator supplied with the heater is preset for the gas shown on the rating plate to the correct pressure. It is an appliance level regulator designed for (low inlet) pressure (less than 1/2 Psig or 15” W.C.) DO NOT connect to an unregulated or high pressure propane line or to a high pressure commercial natural gas line.

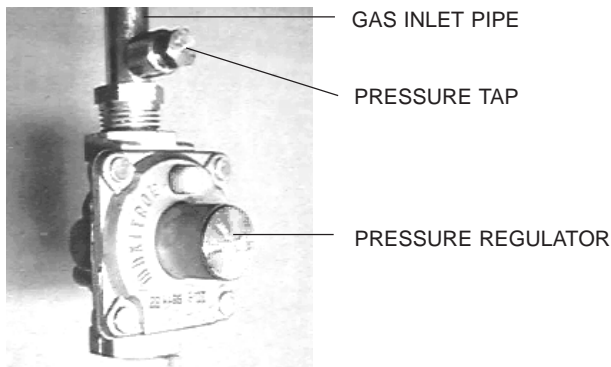

Fig. 4 - Installation of Gas Pressure Regulator

The pressure regulator provided with the heater is adjusted to deliver the proper gas pressure (as indicated on the rating plate and in the manual for altitude up to 2000 feet (660 meters) above sea level. On appliances being installed above 2000 ft (660 meters) elevation, the inlet gas pressure should be set at installation to the value shown below.

NOTE: The gas pressures specified below refer to pressures taken at the test pressure nipple on the gas inlet pipe just above the regulator (See Fig 4). These readings should be taken while the heater is operating at full input — i.e. maximum water flow with the temperature dial selector turned all the way clockwise.

MAXIMUM INLET GAS FLOW PRESSURE SETTING

Altitude	Natural Gas inches W.C:	Liquid Propane inches W.C:
0' - 2.000 ft	5.7"	10.5"
2.000 ft - 4.500 ft	4.6"	8.4"

Above 4.500 ft consult your local gas supplier.

GAS LINE SIZE

It is strongly recommended that the natural gas pipe line be 3/4" for the entire distance. If the maximum length is above 40 feet, use 1" line. Flexible tubing is NOT recommended, but if it is to be used, oversize it. With LP gas installation, the recommended sizes are 5/8" up to a maximum of 20 feet distance, 3/4" up to 50 ft distance and 7/8" up to 100 feet.

National Fuel Gas Code requires that a sediment trap (drip leg) be installed on gas appliances not so equipped. The drip leg must be accessible and not subject to freezing conditions. Install in accordance with the recommendations of the serving gas supplier.

WARNING: The heater must be disconnected from the gas supply piping system during any pressure testing of that system at test pressures in excess of 0.5 psig.

The water heater must be isolated from the gas supply piping system by closing the manual shutoff valve during any pressure testing of the gas supply piping system at test pressures equal to or less than 0.5 psig.

The water heater, including the pressure regulator provided with it, must not be operated at gas supply pressures in excess of 0.5 psig. If overpressure has occurred, such as through improper testing of the gas lines or emergency malfunction of the supply system, the gas valve and regulator must be checked for safe operation. Make sure that the regulator vent is protected against blockage. Vent blockage could occur during ice storms.

When your connections are made, check for gas leaks at all joints (not just the ones you made). Apply some soapy water to all gas fittings and gas valve. **Soap bubbles are a sign of a leak.**

NOTE: Do not apply soap solution to pilot filter screen or pilot orifice area. If you have a leak, shut off the gas. After verifying that required gaskets are in place, tighten appropriate fittings to stop leak. Turn the gas on and check again with a soapy solution. **Never test for gas leaks using a match or flame.**

WATER CONNECTIONS

Although water piping throughout your structure may be other than copper, we recommend that copper piping be used for at least three feet before and after the heater (follow local codes if more stringent). Keep water inlet pipe to no less than 1/2 inch diameter to allow the full flow capacity. Remember that water pressure must be sufficient to activate the heater when drawing hot water from the top floor. If the hot and cold connections to the heater are reversed, the heater will not function. The AquaStar 125B”S” is provided with two water connection adapters that must be connected to the inlet and outlet fittings of the water valve as shown in Fig 5. These fittings seal to the water valve by means of a union connection with a washer type gasket at the joint. No pipe dope or thread tape is to be used at these joints. Be certain there are no loose particles or dirt in the piping. Blow out or flush the lines before connecting to the AquaStar. A ball valve should be installed on the cold water feed line to facilitate servicing the heater.

For installation on a private well system, be sure that the **water pressure** is set between 30 and 50 psi.

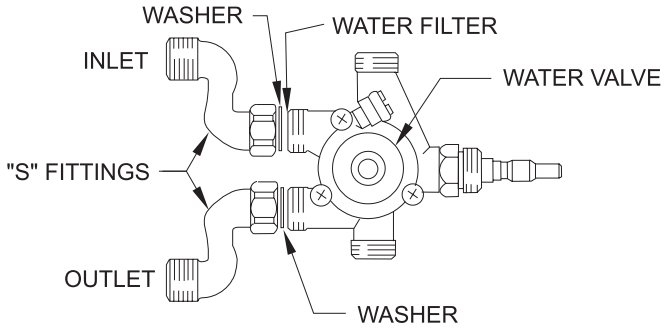

Fig. 5 - Water valve and "S" water connectors, top view

Connecting the pressure relief valve (PRV)

A listed pressure relief valve supplied with the heater must be installed at the time of installation. No valve is to be placed between the PRV and the heater. No reducing coupling or other restriction may be installed in the discharge line. The discharge line must be installed such that it allows complete drainage of both the PRV and the line. The location of the PRV must be readily accessible for servicing or replacement, and be mounted as close to the water heater as possible. See Fig 6. To install the PRV, a suitable fitting connected to an extension on a "T" fitting can be sweated to the hot water line.

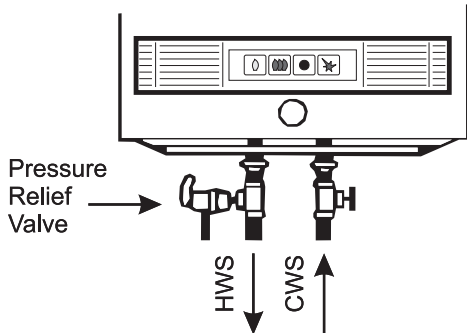

Fig. 6 - Pressure Relief Valve

OPERATING INSTRUCTIONS

Before proceeding with the operation of the heater make sure that the system is filled with water. Make sure the water heater drain plug is closed. See Figure 7 below.

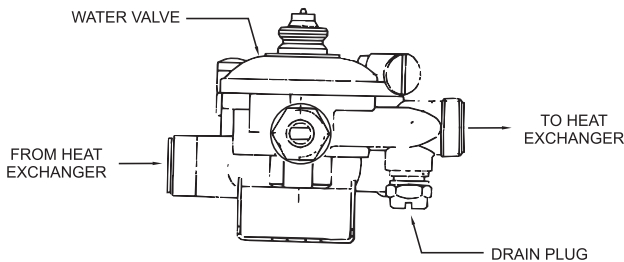

Fig. 7 - Water heater drain plug

Open the cold water inlet supply to the heater fully. Open a hot water faucet to permit the water to fill the heater and the piping and to eliminate the air trapped in the system. Close the hot water faucet after the water flows freely and all the air has escaped from the system. The water heater is now ready to work.

FOR YOUR SAFETY READ BEFORE LIGHTING THE PILOT

Warning: If you do not follow these instructions exactly, a fire or explosion may result causing property damage, personal injury or loss of life

A. This appliance has a piezo-igniter for lighting the pilot burner. When lighting the pilot, follow these instructions exactly.

B. BEFORE LIGHTING smell all around the appliance area for gas. Be sure to smell next to the floor because some gas is heavier than air and will settle on the floor.

WHAT TO DO IF YOU SMELL GAS

- Do not try to light any appliance.
- Do not touch any electric switch; do not use any phone in your building
- Immediately call your gas supplier from a neighbor's phone. Follow the gas supplier's instructions.
- If you cannot reach your gas supplier, call the fire department.

C. Use only your hand to push in or turn the gas control buttons. Never use tools. If a button will not push in, check to make sure the buttons are being pushed in the proper sequence. Follow these instructions exactly. If control button(s) are jammed, close the gas supply and call a qualified service technician. Attempted forceful repair may result in a fire or explosion.

D. Do not use this appliance if any part has been under water. Immediately call a qualified service technician to inspect the appliance and to replace any part of the control system and any gas control which has been under water.

LIGHTING INSTRUCTIONS

1. STOP! Read the safety information above on this plate.
2. The gas valve must be turned off by depressing the gas valve off button (●).
3. Wait five (5) minutes to clear out any gas. If you smell gas, STOP! Follow "B" in the safety information above on this plate. If you don't smell gas, go to the next step.
4. The pilot burner is located behind the peephole in the front center of the jacket directly below this instruction plate.
5. Depress PILOT button (◆) and light pilot by pushing PILOT IGNITER button (⚡). This may have to be repeated.
6. Observe the pilot flame through the peephole. The pilot button (◆) should be held down at least 10 seconds with pilot burning. When the pilot button is released the pilot should continue to burn.
 - If the gas valve button does not pop up when released, stop and immediately call your service technician or gas supplier.
 - If pilot does not stay lit, repeat steps 1 through 6.
 - If pilot will not stay lit after several tries, depress the OFF button (●), and call your service technician or gas supplier.
7. When lit, depress the ON button (◆◆). The heater will now fire when water is drawn at a rate greater than the threshold flow rate.

NOTE: If main burner should fail to ignite, make sure pilot is burning. If not, repeat lighting steps 1 through 6.

TO TURN OFF GAS TO APPLIANCE

Depress the OFF button (●) and close the main gas valve by turning the handle clockwise (↻) to the OFF position.

INFORMATION ABOUT WATER TEMPERATURE

The AquaStar 125B LPS and 125B NGS water heaters have a gas control that modulates burner output in response to water flow. Its purpose is to ensure that the hot water temperature will remain steady, although the water flow demand might vary (down to 1/2 gal/minute). The AquaStar 125 B"S" will produce a temperature rise of approximately 90°F at flow rates between 0.5 and 1.8 gallons per minute unless the water has been preheated. If the incoming water is already hot, the burners will modulate accordingly so the outlet temperature will not exceed 140°F.

Cold water will have to be mixed in at the faucet to produce comfortable temperatures. Mixing in cold water will produce higher flow rates and will reduce risk of scalding. Note: 105° is the maximum recommended temperature for a hot bath. Handwashing should not be done in water hotter than 112° - and cooler for older adults, young children or persons with sensory loss. Remember that scalding can occur in 20 seconds with 135° water.

MAINTENANCE AND SERVICE

Approximately once a year, the AquaStar should be checked, cleaned and serviced as necessary. To remove the front cover, first remove the incandescent particle tray, then unscrew the central screw located at the bottom of the front cover. Pull main cover out toward you and lift up and out. THE FOLLOWING OPERATIONS SHOULD BE PERFORMED BY A QUALIFIED SERVICE PERSON:

Vent System: Should be checked annually. Clean and repair as needed.

Water Valve (Part # 8707002392): The water valve on this heater should be serviced periodically. The frequency will depend on the mineral content of the water and conditions of use or whenever signs of corrosion appear at the gas and water valve joint. Check that the water inlet filter (#35 on Figure 13, page 14) is clean.

Pilot Flame: The pilot flame should burn with a clean sharp blue flame and should resemble the diagram in Fig 8. If the flame is yellow, or if the pilot knob has to remain depressed for a long time in order to keep the pilot lighted, the pilot burner and or the pilot burner orifice may need to be cleaned (NG), the orifice may need to be replaced (LP), and or the air screen may need cleaning. The pilot flame should envelop approximately 10 mm (3/8") of the tip of the thermocouple. If it is too small, the pilot burner must be cleaned. To obtain a spark, the position of the Piezo igniter electrode should be approximately 3 mm (1/8") from the pilot burner tip.

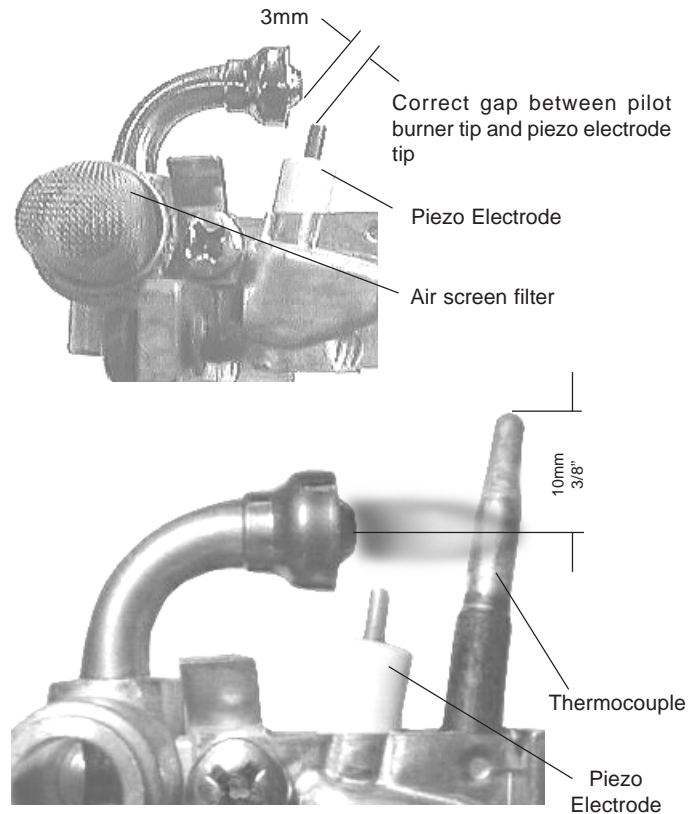

Fig. 8 - Characteristic Pilot Flame

To clean the pilot burner and/ or the pilot orifice : Turn off the gas at the unit. Remove the cover of the heater. To do so, remove incandescent particle tray and unscrew the central screw located at the bottom of the front cover. Pull main cover out toward you and lift up and out. Pull the air screen off, wash it and blow any lint off (See Fig 10). The pilot orifices should also be cleaned or replaced. **Do not enlarge the orifice.** Do not use any wire or sharp object to clean orifices. Natural gas orifices are large enough that you can usually clean them by blowing through them. LP orifices, on the other hand, are too small to clean and should be replaced. See #3 in Trouble Shooting Section. To access the pilot orifice, remove 2 screws holding pilot assembly in place. Then loosen compression fittings to expose pilot orifice.

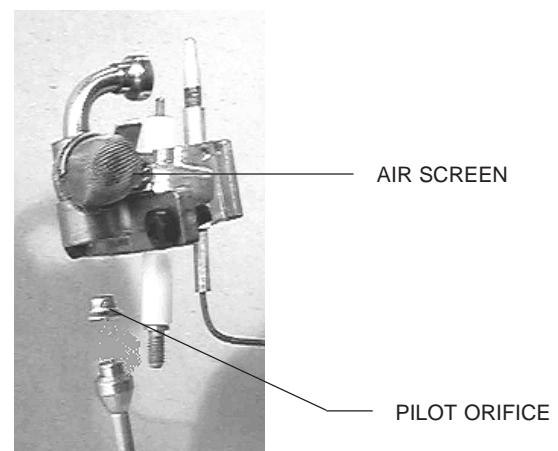

Fig. 9 - Pilot burner with air screen/ pilot orifice

Main Burner Flames: The main burner flames should be blue, with a more intense blue cone in the center core. Yellow flames could be a sign of wrong size gas orifices or

dirty burners, or a blockage on the heat exchangers fins. If some burners have yellow flames while others have good flames, it is likely that dust, lint or spider webs have partially clogged the burner venturis. Contact a gas service person to clean the remove and clean the burners.

Mineral Scale Build-up: AquaStars, tend not to accumulate mineral buildup. If however, the water has a high mineral content, periodic descaling may be necessary. The heating coils should be flushed with a descaling solution. Consult your dealer or Controlled Energy for instructions.

TROUBLE SHOOTING

Introduction

The AquaStar 125 B "S" burners are activated by a water flow valve. Numerous water related problems can cause this water valve to malfunction such as: Insufficient water flow volume to activate the burners at its minimum flow requirement; Dirt in the water flow valve causing it to malfunction; Sediment build-up in faucet aerators, or shower heads; Uneven pressures between cold and hot. (with single lever faucets) Plumbing cross overs. These water flow related problems can cause the heater to deliver less than its full output, or to fail to ignite or to shut down completely.

Problems are stated in upper case, bold face. Most common causes for the problems follow in order of likelihood. The suggested solutions require that the cover be taken off. To do this, remove incandescent particle tray and unscrew the central screw located at the bottom of the front cover. Pull main cover out toward you and lift up and out.

PILOT LIGHT WILL NOT LIGHT

1. No gas to the AquaStar

- A. Gas cock on gas line may not be open.
- B. Gas valve button has not been pushed in on "PILOT" position ().
- C. Gas regulator may be shut or damaged.

2. In-line AquaStar gas regulator jammed (usually on LP gas)

Replace or unjam the regulator. **Note:** The regulator furnished with the heater is designed for low gas pressure. Excessive pressure will lock it up (propane only). Jamming usually happens if the gas pressure between the gas tank (propane) and the water heater's gas regulator has not been reduced. See page 2 for recommended correct gas pressure. To unjam a regulator, consult your gas supplier.

3. Pilot orifice clogged and/or air screen dirty, or pilot gas filter is dirty.

Clogging of the pilot burner can be caused by dust and any suspended matter contained in the ambient air. Although the filters can lengthen the cleaning intervals, they can never completely prevent such clogging. In consequence the gas jet issuing from the pilot orifice is reduced and or the air mixture is reduced. The pilot flame is weak and thus can no longer heat the thermocouple sufficiently. For cleaning purposes, the air filter screen is

pulled off, washed and blown out. The pilot orifice has likewise to be cleaned or exchanged. Consult a gas service person to clean the pilot.

4. Air in the Gas Line

Note: Normally this is a problem only at the time of initial installation, after the pipes have been worked on, or after a propane tank has been allowed to empty, or after the heater has been shut down for a long time.

Bleed all the air trapped in the gas line. Because of the very small pilot orifice (especially on LP gas models), bleeding out all the air could take several minutes. Depress the pilot button () and depress this button until all the air has escaped, and the gas has arrived. During this process, press repeatedly on the piezo ignition button until the pilot flame has ignited.

PILOT LIGHTS BUT FLAME GOES OUT WHEN BUTTON IS RELEASED

1. Pilot push button was not pushed in far enough or was not held in long enough

Depress the pilot button. Hold it pushed in for at least 15 seconds to give time for the pilot flame to properly heat the tip of the thermocouple.

2. Pilot flame improperly aimed or is too weak so it is not properly heating the tip of the thermocouple.

The Pilot flame should be a sharp blue flame and aimed at the tip of the thermocouple so that it envelops 10 mm (3/8") of the thermocouple tip. Pilot flame has to be properly aimed at the thermocouple. See Fig 8.

3. Poor thermocouple connection at the electromagnet

Note: Electromagnet is part #8707201094 located on the right side of the gas valve behind the piezo pushbutton assembly. Check the tightness of the thermocouple connection nut at the electromagnet: The Electro-magnet connection is a large aluminum 17mm hex head nut. The thermocouple end is a 5 mm brass nut which screws into the 17 mm nut. Tighten the thermocouple nut snugly but not too tight.

4. Poor circuit connections at the ECO. (Energy Cut-Off overheat protection)

Oxidation or looseness of the ECO terminal connections can result in millivolt current loss through the thermocouple safety circuit. Clean terminals with very fine sand paper or an eraser and reconnect ECO leads.

5. Faulty ECO (part #8707206017)

If cleaning the terminals attached to the ECO did not fix the problem, connect a jumper wire between the two wires and try to relight the pilot. If the pilot flame now remains on, replace the ECO. If the flame still goes out when the button is released, the ECO is not defective. Go to next step.

6. Faulty thermocouple (part #8747202078) or electromagnet) Unless these 2 parts are at least 8 to 10 years old, it is very unlikely that they are faulty. Before testing, reconfirm that #2 is absolutely correct, and that all connections are clean and tight.

BURNERS DO NOT IGNITE WHEN HOT WATER IS TURNED ON

1. Pilot is not on.

Light the pilot. See lighting instructions.

2. Gas valve button not positioned on Burner Position

Be sure once the pilot flame is on, that after a 15 to 20 second wait, the main burner button () is pushed all the way in.

3. Cold incoming water connection made to wrong side of heater

Make sure cold water inlet connection is on the right side of heater when you are facing the heater.

4. Water flow rate at hot water tap is too low.

Note: The AquaStar models 125B”S” require 0.5 gallon per minute flow to activate the burners. This is a flow which would fill a quart jar in 30 seconds.

5. Cold water inlet filter on heater is dirty.

Remove filter and clean. This screen filter is located at the inlet side of the brass water valve (fig. 11, #35). Check and clean faucet aerators too.

6. Crossover in household plumbing

The AquaStar burner activates when there is sufficient water pressure drop in the AquaStar water valve assembly — ie. when a hot water faucet is opened. If there is a crossover in the plumbing, the necessary pressure drop in the AquaStar will be insufficient, or totally eliminated. A plumbing crossover can be caused by a bad washer at a single lever faucet or incorrect plumbing or a mixing valve in the line, etc. which permits hot and cold water to mix in the plumbing. The crossover will create a back pressure in the system preventing the pressure drop in the Aquastar — i.e. cold water is entering the water heater from both sides and the burners will not come on. To confirm there is no crossover in the plumbing, shut off the cold water supply to the AquaStar. Open your hot water taps. There should not be any water flowing. If there is water flowing, there is a crossover in the plumbing. This is a plumbing problem, not an Aquastar problem. Please contact your plumber.

7. Water valve parts may be dirty or components damaged.

Water valve and component parts must be totally free of dirt. First check that the venturi is free of dirt particles. In hard water areas, mineral deposits can eventually (3 to 5 years in hard water areas) corrode the water valve parts to a point where they will need replacing. *Any sign of moisture or corrosion at the joint of the water valve and the gas valve is a sign that the water valve assembly components need to be replaced immediately.*

Note: Water valve for model 125B”S” is part # 8707002380 for both LP and NG models. (Contact service person to clean water valve or replace if corrosion is present).

PILOT LIGHT GOES OUT DURING OR IMMEDIATELY AFTER HOT WATER HAS BEEN USED

1. Gas pressure too low

Very low gas pressure may be caused by low delivered gas pressure, a jammed gas regulator or undersized gas lines. If the gas lines are undersized, there may still be the specified static gas line pressure. However when the water valve opens, and gas enters the burners, the pressure could drop sharply, causing the pilot flame to go out. Have a gas technician confirm the gas pressure both static and at maximum Btu output. Specifications for your heater are on page 2.

2. Pilot may be dirty or weak

See Page 9 for instructions on pilot maintenance.

3. Burners are not shutting down immediately when hot water is turned off

Note: If burners don't shut down immediately when the hot water is turned off, the heater will overheat and the ECO will shut-off the gas. Rebuild the water valve assembly using the repair kit from CEC (part #8 703 406 204).

WATER IS TOO HOT

1. Water flow rate is too low.

Increase the flow rate.

2. Not enough cold water mixing at faucet

Contact your plumber to adjust mixing valves on faucets.

WATER IS NOT HOT ENOUGH

1. Water flow rate is too high.

Decrease the flow rate.

2. Btu input is too low due to insufficient gas pressure *It is extremely important for a tankless instantaneous water heater to have the right size gas line to obtain the correct gas pressure*

See specifications on page 2. Unlike storage tank water heaters, the burners of a tankless water heater must be very powerful to heat water instantaneously since they do this only at the time hot water is actually being used. It is therefore imperative that the gas pressure requirement be met exactly. Insufficient gas pressure will directly affect the water temperature at the time of usage. See page 2 for correct gas pressure settings.

3. Thermostat calibration is incorrect or thermostat is defective.

Contact your service person or call CEC.

4. Btu input is too low due to insufficient gas supply

Make sure your main gas line is fully opened. If using LP gas, be sure that the size of the propane tank is adequate to supply the required gas pressure.

5. Cold water is mixing with the hot water between the AquaStar and the outlet

Compare water temperature at outlet of the AquaStar (hold

the AquaStar's outlet pipe with your hand) and at the tap. If these two are very different, check for mixing valve or plumbing crossover (see "MAIN BURNERS WILL NOT IGNITE..." paragraph #6).

6. Parts in water flow valve are corroded so that the gas passage is not fully opening.

Contact your service person or Controlled Energy.

HOT WATER TEMPERATURE FLUCTUATES

1. Unbalanced pressure in waterlines

The added restriction caused by the Aquastar in the hot water system can result in uneven pressures between the cold and the hot. In such cases when mixing cold water at the tap, the lower hot water pressure may be overpowered by a much higher cold water pressure, which may cause the Aquastar burners to shut down. Make sure faucet aerators or shower heads are free of minerals. **Do not add any flow restrictor to the shower head.**

2. Inlet water pressure is erratic due to inadequate supply water pressure or saturated pressure tank on well system

Check the inlet water pressure. On a private well, raise minimum pressure setting to 30 psi. Confirm that the pressure tank is not water logged.

3. Cold water is mixing with the hot water between the AquaStar and the outlet

See #6 under "MAIN BURNERS DO NOT IGNITE WHEN HOT WATER TURNED ON".

4 . Insufficient gas pressure

Note required gas pressures (page 2) and consult gas service person.

Fig. 10 - Diagram of AquaStar 125 B"S"

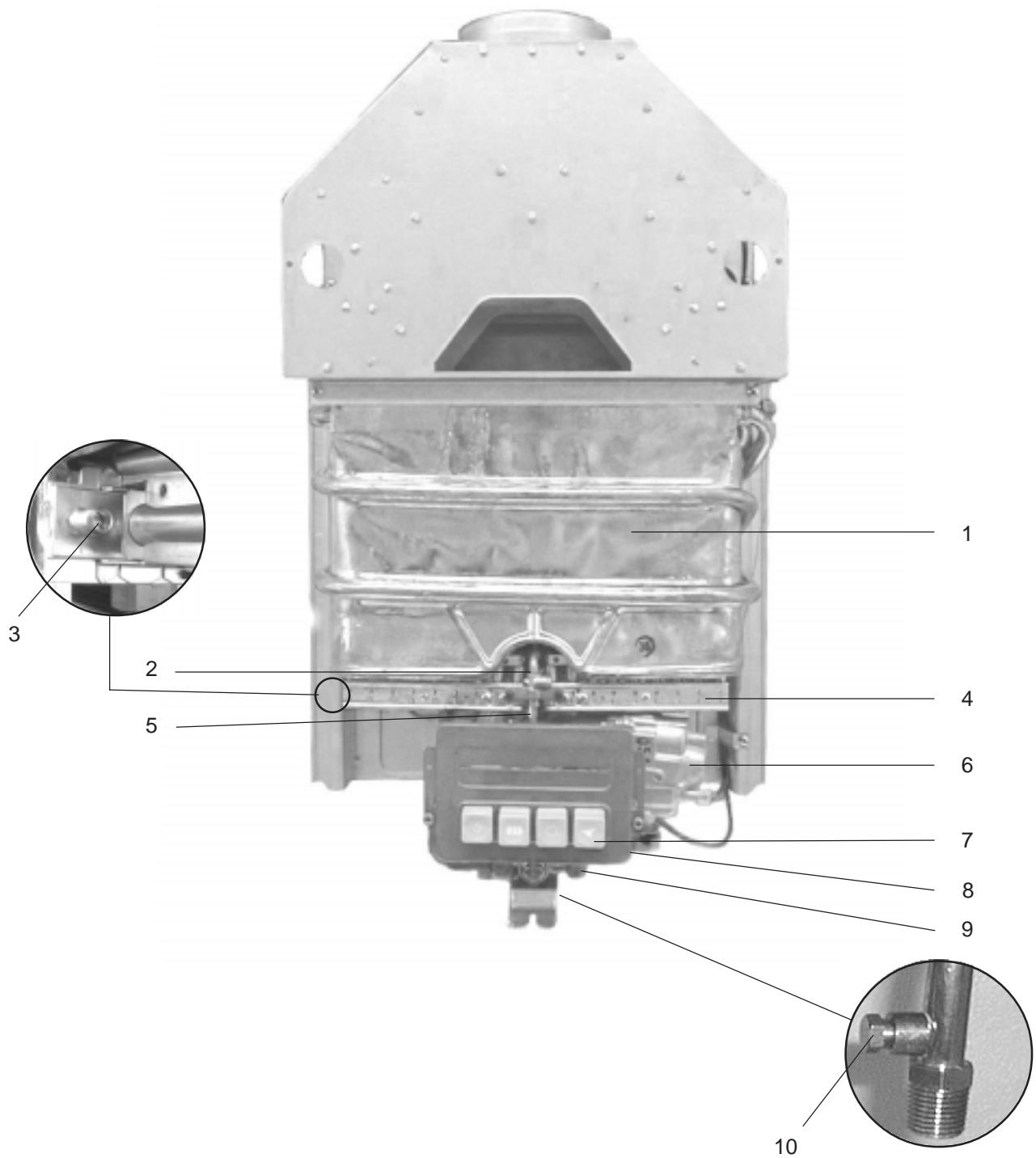

- | | | | |
|----|---|-----|---------------------------------------|
| 1. | Heat exchanger | 6. | Gas valve |
| 2. | Pilot assembly | 7. | Piezo igniter |
| 3. | Burner manifold gas
pressure test nipple | 8. | Location of pressure tap
screw |
| 4. | Main gas burner | 9. | Water valve |
| 5. | Pilot gas tubing | 10. | Gas inlet gas pressure
test nipple |

AQ 125 BS

Fig. 11 - INTERIOR COMPONENTS DIAGRAM AND PARTS LIST

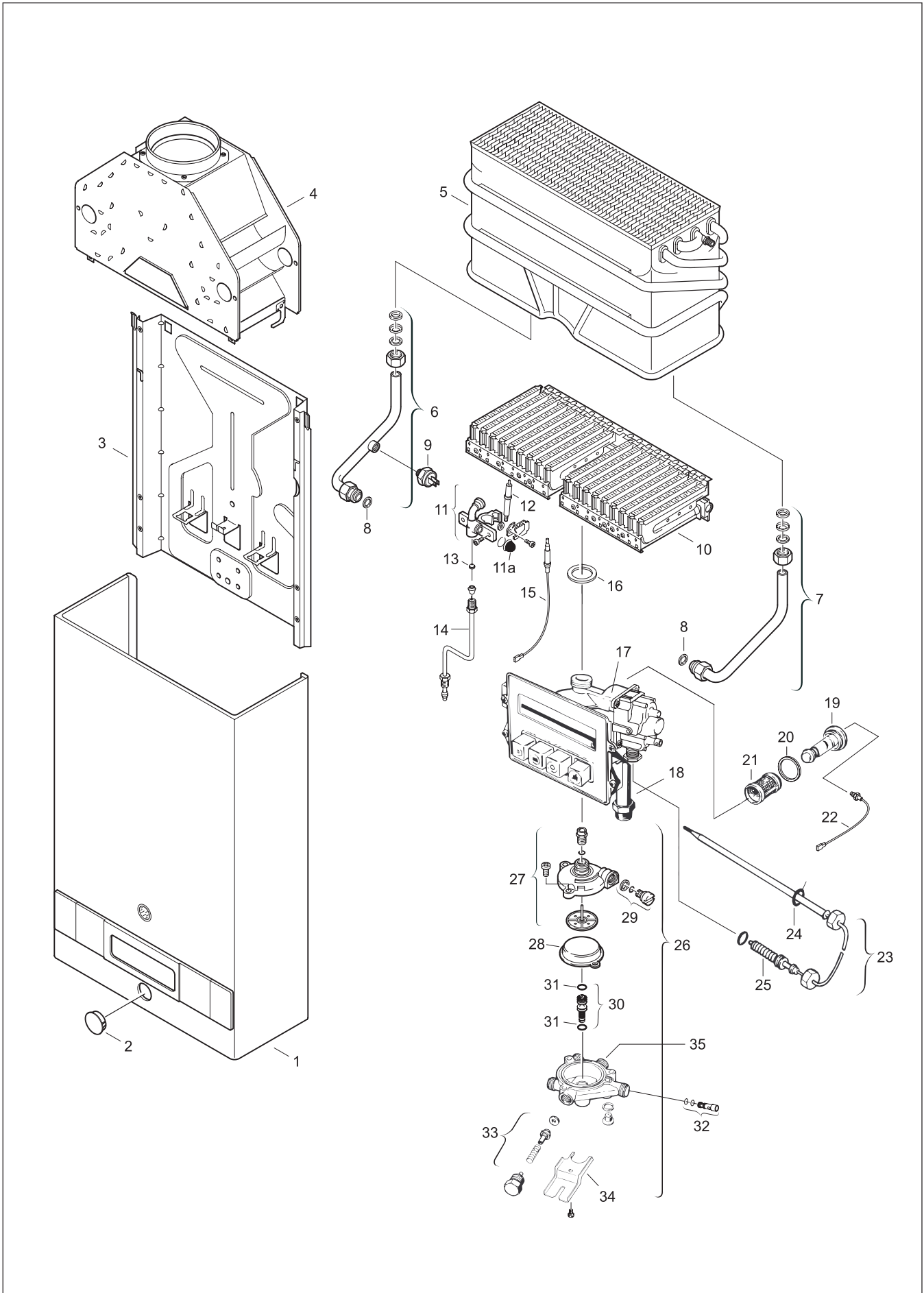

Fig. 11

**INTERIOR COMPONENTS DIAGRAM
AND PARTS LIST 125BS**

1	Cover	8 705 421 033
2	Cap cover	8 703 304 011
3	Panel back	8 705 402 164
4	Draft divertor	8 705 505 354
5	Heat exchanger	8 705 406 189
6	Hot water pipe	8 700 705 431
7	Cold water pipe	8 700 705 294
8	Heat exchanger washer	8 710 103 045
9	Overheat sensor (ECO)	8 707 206 017
10	Main burner assembly LP	8 708 120 296
	Main burner assembly NG	8 708 120 298
11	Pilot burner assembly	8 718 105 048
11a	Pilot filter screen	8 700 507 055
12	Piezo electrode	8 708 107 002
13	Pilot orifice NG	8 708 200 005
	Pilot orifice LP	8 748 200 173
14	Pilot Tube	8 700 707 316
15	Thermocouple	8 747 202 083
16	Burner assembly washer	8 710 103 060
17	Gas valve LP	8 707 011 467
	Gas valve NG	8 707 011 469
18	Gas supply pipe	8 700 705 464
19	Electromagnet	8 707 201 094
20	Electromagnet washer	8 700 103 144
21	Gas filter	8 700 507 051
22	Thermocable	8 747 202 078
23	Thermostat	8 707 206 039
24	O ring Thermostat	8 700 205 101
25	O ring Thermostat	8 700 205 041
26	Water valve assembly	8 707 002 392
27	Water valve repair kit	8 703 406 204
28	Water valve diaphragm	8 700 503 012
29	Slow ignition valve	8 708 503 062
30	Water valve setting screw	8 703 404 092
31	O ring setting screw	8 700 205 050
32	Water valve venturi	8 708 205 235
33	Water valve piston assembly	8 708 500 230
34	Holding bracket	8 701 309 040
35	Water inlet filter	8 700 507 045



INSTALLATION CHECKLIST

GAS LINE SIZE

Natural Gas

Nominal Iron Pipe Size*	1/2"	3/4"	1"	
MAXIMUM LENGTH	10'	40'	150'	

Liquid Propane

Semi-rigid Tubing	1/2"	5/8"	3/4"	7/8"
MAXIMUM LENGTH	NOT RECOMMENDED	20'	60'	150'

* Flex tubing greatly reduces capacity and, therefore, is not recommended.

Minimum Vent Size* and Height

Minimum Diameter	Minimum Height**
5 inches	6 feet**

* **NOTE:** Vent size must not be restricted. Installation must comply with national fuel gas code venting requirements for a 117,000 Btu Category I appliance and any applicable local codes.

** **NOTE:** Minimum vent height must be 6 feet, provided there are no elbows. Termination of the vent must be 2 feet above any obstruction within a 10 foot radius of vent pipe. Consult your gas utility or National Fuel Gas Code if vent will have elbows or share venting with another appliance. The vent connector should have as much vertical rise as possible (minimum 12") before any horizontal run.

Water Pressure

For installation on well systems, insure that your water pressure is between 30 - 50 psi.

Replacement Parts available from North American Distributor

CONTROLLED ENERGY CORP.

340 Mad River Park
 Vermont 05673 (U.S.A.)
 Phone 800-642-3111
 Fax (802) 496-6924

WWW.CECHOT.COM techsupport@cechot.com

VULCANO Termodomésticos S.A.
 Estrada de Cacia
 3800 Cacia - PORTUGAL